

Si-30

mini condensate removal pump



N006_00 édition 14/07

www.sauermannpumps.us

Manufactured to



specification

- › Engineered in partnership
- › Best-in-class reliability, manufactured specifically for condensate removal
- › Patented 5 gph pump technology
- › Specific wiring schematic for Daikin models (see reverse page)
- › Complete with Drain Safe Device

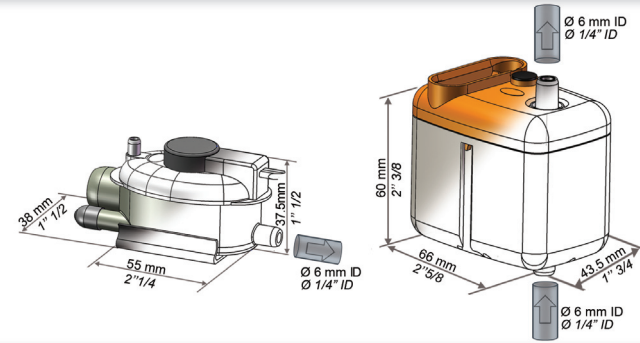

ONE PUMP



- One pump suitable for ALL Daikin models from 0 to 42 kBtu/hr (12.5 kW – 3.5 tons)
- 5 gph
- High capacity, less run time = RELIABILITY



SILENT OPERATION

- High performance with low operating sound levels
- Flexible & Easy to install and maintain
- Ideal for Bedroom use



COMPLETE INSTALLATION KIT INCLUDED

Everything you need for a complete installation

- Unique self sealing discharge fitting included
- Drain Safe Device
Combines mechanical and gravity drain
Allows condensates to clear efficiently, keeping the pump primed at all times.



DACA-CP3-1

(230V) RA, RA MULTI & QUATERNITY INDOOR UNITS

Models: (FTXN09, 12 KEVJU) (FTXN15, 18, 24 KVJU) (FTXS09, 12, 15, 18, 24 LVJU) (FTXG09, 12, 15 HVJU) (CTXS07 LVJU) (CTXS09, 12 HVJU) (FDXS09, 12 LVJU) (CDXS15, 18, 24 LVJU)



WIRING SCHEMATIC

Si-30



DACA-CP3-1

(230V) VRV & SKYAIR SERIES INDOOR UNITS

Models with WHITE Jumper
SkyAir: (FHQ18, 24, 30 PVJU) (FHQ36, 42 MVJU)
VRV: (FXHQ12, 24, 36 MVJU) (FXLQ12, 18, 24 MVJU) (FXNQ12, 18, 24 MVJU)
Models with GREEN Jumper
SkyAir: (FAQ18, 24 PVJU) (FTXS30, 36 LVJU)
VRV: (FXAQ07, 09, 12, 18, 24 PVJU)



WIRING SCHEMATIC

Si-30

